

SMARTEC

Contact: marketing@smartec-tools.com

Coolant Rings

Coolant Ring – Metric

No.	Cat No.	Cutting Tool Size [mm]	Ring OD [mm]	Ring Length L [mm]	Air Tube ID [mm]	No. of Jets
1	RM03	3	15	9	4	1
2	RM04	4	15.5	9	4	1
3	RM06	6	17	9	4	1
4	RM08	8	19	9	4	1
5	RM10	10	22	10	4	3
6	RM12	12	24	10	4	3
7	RM14	14	26	10	4	3
8	RM16	16	28	10	4	3
9	RM18	18	30	10	4	3
10	RM20	20	32	10	4	3

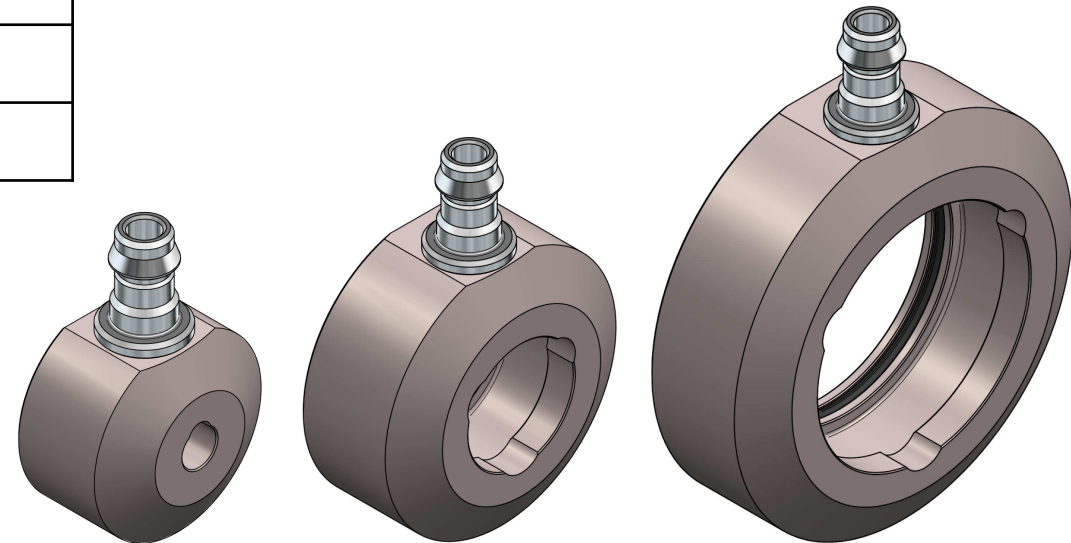
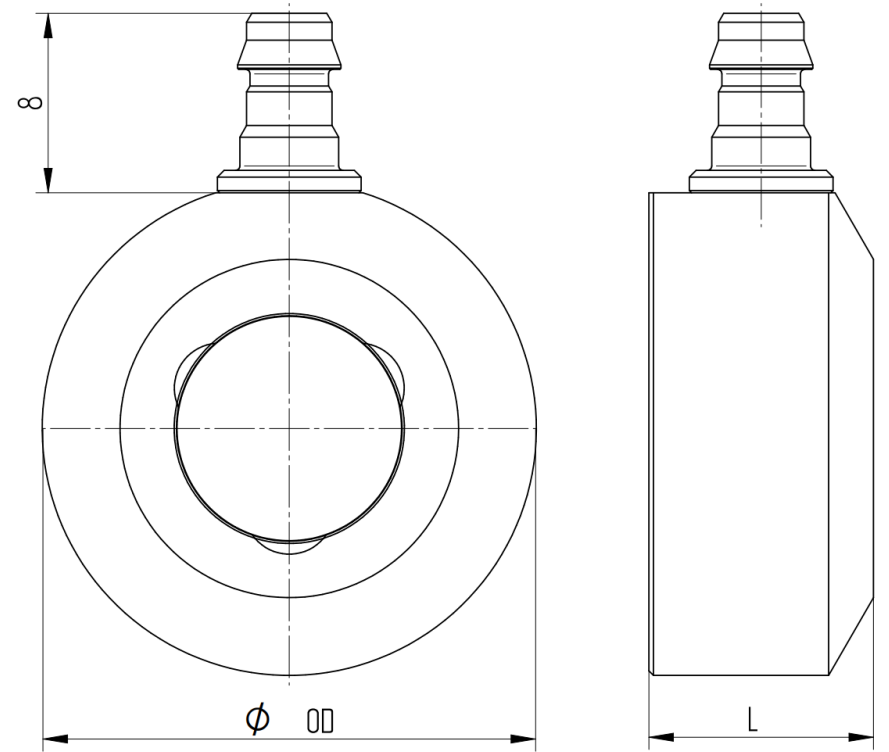

Coolant Ring – Imperial

No.	Cat No.	Cutting Tool Size [inch]	Ring OD [mm]	Ring Length L [mm]	Air Tube ID [inch]	No. of Jets
1	RI08	1/8"	15	9	5/32"	1
2	RI10	5/32"	15.5	9	5/32"	1
3	RI16	1/4"	17	9	5/32"	1
4	RI20	5/16"	19	9	5/32"	1
5	RI24	3/8"	22	10	5/32"	3
6	RI32	1/2"	24	10	5/32"	3
7	RI36	9/16"	26	10	5/32"	3
8	RI40	5/8"	28	10	5/32"	3
9	RI44	11/16"	30	10	5/32"	3
10	RI48	3/4"	32	10	5/32"	3

